



VCOMFORT

Massage Chairs



User Manual

T-ROK 3D

Welcome to VComfort

Thank you and congratulations on purchasing a VComfort Massage Chair - you've made a great choice.

With half a decade of experience designing, building and servicing massage chairs, VComfort takes pride in every chair sold, including yours. We are here for you. The UK based Customer Care team can be reached at 0333 577 9597 or visit us online at www.vcomfort.co.uk.

Inside this manual, you will find everything you need to setup and safely enjoy your chair. Please review the entire manual before using your chair.

Get ready to sit back, relax and enjoy the exceptional Massage Experience.

Limited Warranty

We're confident that your new massage chair will provide you with many years of relaxation and trouble-free performance.

VComfort supply quality massage chairs that are built to last, your massage chair comes with a 1 year manufacturer's warranty for home use as standard to protect against manufacturing faults and defects that occur during this warranty period.

Warranty Limitations and Exclusions

Warranties do not cover any loss or damage resulting from: improper installation; unauthorized repairs; use in a commercial or corporate setting; alterations or modifications of original condition; improper use of electrical/power supply; loss of power; electrical disturbances and power surges; dropped product, including but not limited to remote controls; a malfunction or damage resulting from improper use or unreasonable use or maintenance; failure to follow operating instructions; transportation damage; theft; abuse; misuse; neglect; vandalism; or environmental conditions (fire, floods, rust, corrosion, sand, dirt, windstorm, hail, earthquake, or exposure to weather conditions); loss of use during the period the product is at a repair facility or otherwise awaiting parts or repair; and products purchased or acquired from unauthorized dealers. This warranty is not transferrable. Damage incurred due to shipping and handling does not constitute a defect under this warranty.

Warranty Registration (Home Use)

Register your product at www.vcomfort.co.uk/standard-warranty to ensure it is in our system. This will simplify the warranty process should you ever need it. Alternatively, **scan the QR code** to go directly to the URL above.



Warranty Registration (Commercial Use)

Our warranty for commercial use is 6 months.
Register your product at www.vcomfort.co.uk/commercial-warranty

We know you can't wait to sit in your new VComfort Massage chair! Take a picture of yourself enjoying the exceptional massage experience and make sure to tag us on social media with the hashtag [#vcomfortmassagechairs](https://www.instagram.com/vcomfortmassagechairs)

Staying Safe

Safety Information

To ensure safe use of the massage chair and avoid injury or unsafe conditions, please read and follow all instructions before using product.

Household use only

WARNING

USAGE NOT RECOMMENDED FOR CERTAIN PEOPLE

Use of massage chair may not be safe or suitable for people with certain medical conditions and could cause serious injury or death in some circumstances. If you have any of the following conditions, please consult a physician before using the massage chair:

- Use of implanted electronic medical devices (such as a cardiac pacemaker)
- Pregnancy
- Cancer, malignant tumours, or other growths
- Osteoporosis or spinal fracture
- Other fractures or musculoskeletal injuries
- Loss of or reduced sensitivity to heat
- Implanted medical fixation devices such as rods, pins, etc.
- Recent surgery or sutures
- Skin diseases or skin injury
- High fever
- Certain pulmonary or breathing conditions
- Impaired circulation

WARNING

To avoid possible death or serious injury to user or others, please read and follow these instructions:

WARNING

- The areas under the footrest and behind the back rest are potentially dangerous for a child or pet. The chair back is heavy and reclines with force. A small child or pet located behind the chair could be crushed as chair is being reclined resulting in serious injury. When chair is reclined, small children or pets who have crawled under the leg rest may not be visible to the user and could be crushed when chair is returned to upright position. To avoid serious injury or death, check these areas carefully before reclining, or returning chair to upright position.
- Chair should not be used by children under age 14. Small children could be trapped or injured by airbags, heating mechanism, or moving parts. When chair is not in use, unplug unit and secure chair so that children cannot accidentally power on and operate chair.
- Children over age 14, people with reduced physical, sensory, or mental capabilities, and elderly or frail people should exercise caution and use massage chair only when supervised or assisted by a person over 18 years of age.
- Chair has a heated surface and could cause burns, particularly in people with reduced sensitivity to heat. Such people should use the chair only after consulting with a physician and should use extreme caution during any physician-approved use.

CAUTION

To avoid the risk of minor injury or discomfort, or damage to the massage chair or other property, please read and follow these instructions for safe use of the massage chair:

CAUTION

- Do not stand or stack heavy objects on footrest.
- Do not operate heating features of chair while under a blanket or pillow. Excessive heating can occur and cause fire, electric shock, or injury to people.
- To avoid pinching or crushing, please do not place body parts, especially fingers and toes, between parts of chair and keep clear of moving parts.
- To avoid overheating, injury or discomfort from overuse, do not fall asleep while using massage chair and do not use for extended periods of time (longer than 20 minutes).
- Avoid use while under the influence of alcohol, medications or other substances that may cause drowsiness, disorientation, or impairment of judgment or motor skills.
- Do not use the massage chair right after a meal, as it may cause discomfort.
- If you feel any abnormal discomfort during the operation of the massage chair, turn off the power immediately and discontinue use.
- Do not use this appliance when ambient temperature is over 40° C (104 F).
- Do not use this appliance in humid or dusty environment, or when any part of the body is in contact with plumbing or any similar ground.
- Do not use outdoors.
- Do not operate where aerosol (spray) products are being used or where oxygen is being administered.
- Place the product on a flat, level floor to reduce risk of tipping or overturning.
- Do not use or store near heat or open flame.
- Intended only for users who weigh below 110 kg.
- Use this product only for its intended use as described in this manual.
- Massage chair intended only for use by one person. Do not use by two or more people at the same time to avoid damage to the product.
- Do not allow children to stand, jump, or play on or around massage chair, even when it is not powered on or in use.
- Remove personal accessories such as jewellery from arms and empty pockets, and remove loose clothing while using the massage features of the chair.
- Check the upholstery under the cushions and other spots for damage or loose objects that may cause injury or damage chair while operating. If any damage is present, do not use the massage chair and refer to a qualified service professional for servicing.
- To avoid damage to chair, walls, or other objects, make sure there are no obstacles behind the chair and there is enough clearance before adjusting the backrest or leg rest angle.
- Please be seated properly while using the product.
- To avoid damage to chair or floors, do not drag or push the chair or roll its casters on wood floor or carpet. See instructions for safely moving chair.

WARNING

Read and follow these instructions concerning safe use of the power cord and power unit to avoid possible electric shock, fire hazard, use of chair by and injury to unattended children, or damage to chair or other property.

WARNING

- To avoid risk of electric shock, connect this unit to a properly grounded outlet only.
- Always unplug massage chair from the electrical outlet immediately after use and before cleaning. An appliance should never be left unattended when plugged in. To disconnect, turn all controls to the off position, then remove plug from outlet.
- Do not use massage chair and unplug from outlet during thunder or lightning storms, and before putting on or taking off parts.
- To ensure safe operation, power must be supplied only at standard 220~240 voltage, to the specifications of the appliance. Confirm that the power voltage stated on the rating label corresponds to your local electricity supply.
- The massage chair should be used only with the power supply unit provided. Do not use with any other power source.
- Do not use a wet or damp hand to unplug the cord to avoid electric shock.
- Do not pull on the power cord to unplug. Grip by plastic end nearest outlet to unplug power cord.
- Do not squeeze, over bend, pull hard, or twist the power cord.
- Keep the power cord away from heated surfaces.
- Do not carry or drag the chair by power cord or use cord as a handle.
- If there is any smoke or unusual smell while using massage chair, stop using immediately and unplug the power cord.
- Never operate the chair if it has a damaged power cord or plug. If the power cord is damaged, it must be replaced by the manufacturer or its service agent or a similarly qualified person to avoid a hazard.

Do not disassemble, dismantle or attempt to repair massage chair. Such actions, as well as misuse of product, may cause damage to or failure of massage chair and may void the manufacturer's warranty. For repairs, please contact VComfort at 0333 577 9597.

Contents

Your Chair

Chair Features	7
External Structure	8

Before Getting Started

Installation Site	9
Clearance Space for the Chair	9
Floor Protection	9
Connect the Remote	10
Moving Your Massage Chair	11
Connect to Power	11

Chair Setup

Main Power Switch	12
Adjust Pillow	12
Getting Out of the Chair	13
Chair Entry and Exit Hazards	13
Remote Control	14
Remote Control Operations	15
Auto Programmes	16
Manual Massage Techniques	16
Environment	17
FAQs	18
Trouble Shooting	19
Specifications	19

Chair Features

- SL-Track
- 3D Massage Mechanism
- Airbag Compression Therapy
- Six Auto Massage Programmes
- Manual Massage Techniques
- Zero Gravity
- Lumbar Heat
- Manual Footrest Extension
- Bluetooth Speakers

Your Chair

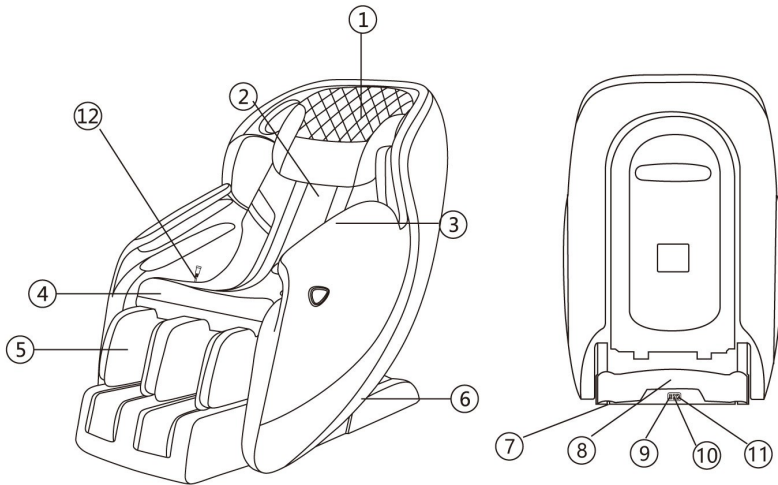

1. Pillow

4. Seat Cushion

7. Casters

10. Power Switch

2. Back Cushion

5. Calf Airbags

8. Power Control Box

11. Fuse

3. Armrest

6. Side Panel

9. Power Cord Receptacle

12. Controller Cord Receptacle

Before Getting Started

Installation Site

Clearance Space for the Chair

- 26cm clearance for the recline of the backrest; 20cm clearance for the extension of footrest and sliding forward of the chair.
- Keep it 3 feet away from the TV, radio or other audio & video appliance to avoid signal interference

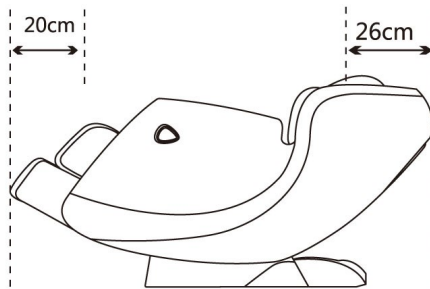

In order to avoid injury or damage before reclining - check to make sure area is clear of children, pets, or obstacles.

Floor Protection

To protect ANY floor type, hard surface or carpeted, from scratches or other markings, place the chair on a sacrificial pad or mat that extends from under the footrest to the rear of the chair.

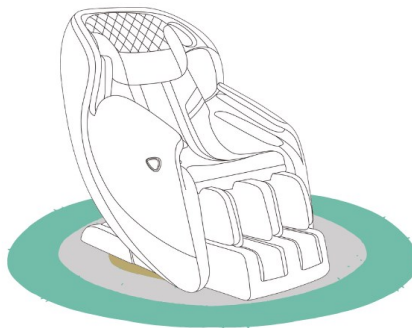

In order to avoid damage or injury, do not place the massage chair on a wet or uneven floor.

Do not operate the chair in wet or damp environment to prevent electric shock accident.
Do not operate the chair under direct sunlight or near heated sources or surfaces to avoid fire hazard or damage to the product.

Connecting the Remote

Connect the remote control cable to the massage chair's plug connector, then tighten the cap clockwise to secure the connector in place.

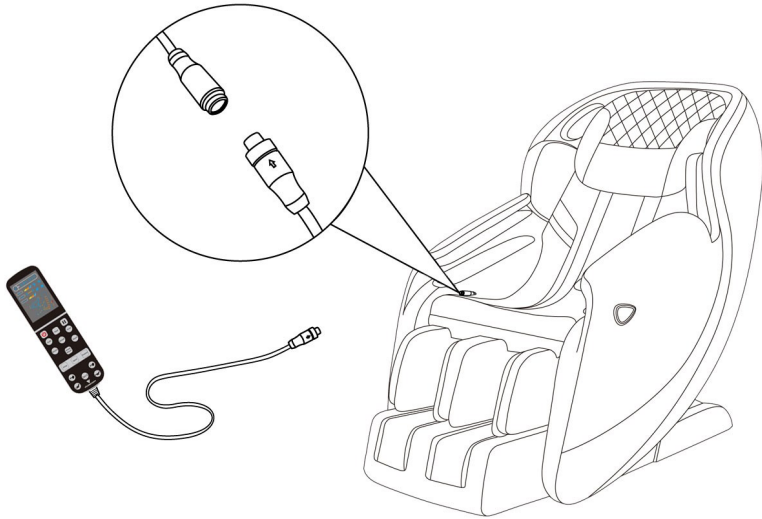

Moving Your Massage Chair

Your massage chair is equipped with castors for moving the chair - follow the below steps.

- Stand behind the massage chair and apply pressure downward to the back of the massage chair to pivot on the Castors.
- Have a second person up front to guide the footrest until in the correct position. Gently lower into place.
- Slowly push and manoeuvre the massage chair to the desired location.
- Gently lower the chair slowly until it is fully flat on the floor.

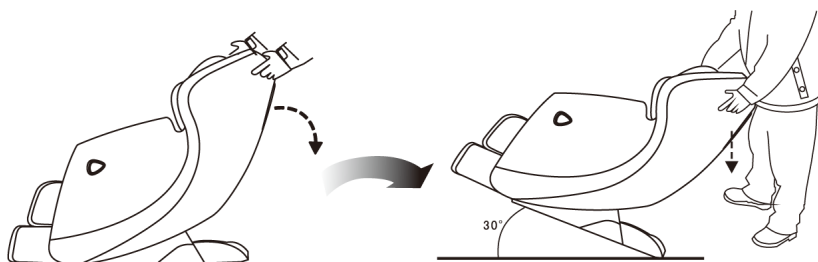

Do not move the chair when there is user inside.

Do not lift chair by footrest or armrests to avoid injury and damage to product

Place a protective floor mat under the massage chair during normal usage and movement to prevent to prevent damage to flooring.

Connect to Power

Please make sure to plug the power plug into a dedicated 220~240V outlet.

WARNING

- Use only with properly grounded outlet (3 prong). Do not plug into ungrounded outlet.
- To avoid risk of electrical shock, turn power switch off before plugging unit into electrical outlet
- Do not use multiple devices simultaneously when using a multi outlet adapter.
- Do not touch the power plug with wet hands. Always disconnect the power plug when cleaning.
- There is a risk of electric shock
- Risk of fire due to overheating of the outlet

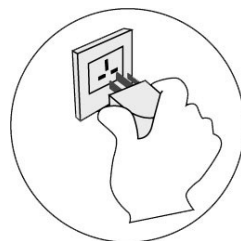

Chair Setup

Main Power Switch

To power up the chair, flip the main power switch located on the back of the base of the chair to ON.

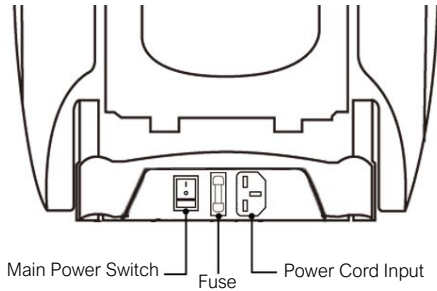

To avoid possible damage to product or injury to unsupervised children, always turn off power switch and unplug massage chair from electrical outlet immediately after use.

When not in use for a long period of time, we recommend that the chair be covered, the power cord be coiled and that the unit be placed in an environment free of dust and moisture.

Adjust Pillow

Take a seat in the chair and take note of where the neck pillow rests on your neck. Adjust the pillow so that it rests comfortably in the arch of your neck.

Smart Tip: To increase intensity in the neck and shoulder region, flip the pillow or the pillow pad up so you lay directly on the seat back pad.

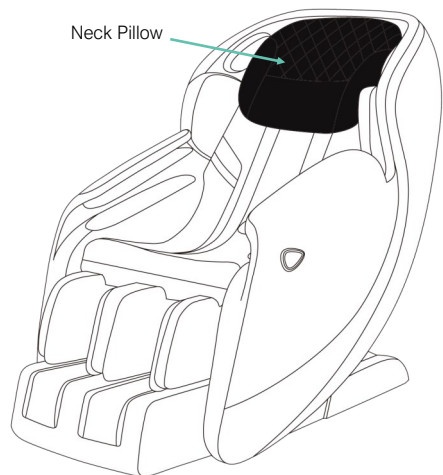

Getting out of the Chair

To easily exit the chair at any time, press the ON/OFF power button on the remote control to restore the chair to the upright position.

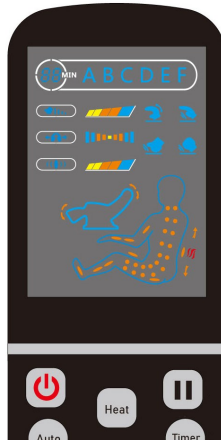

Check to make sure children and pets are clear of chair before pressing on/off button to return chair to upright position.

Chair Entry and Exit Hazards

WARNING: The areas under the footrest and behind the back rest are potentially dangerous for a child or pet. The chair back is heavy and reclines with force. A small child or pet located behind the chair could be crushed as chair is reclined resulting in serious injury or death. When chair is reclined, small children or pets who have crawled under the leg rest may not be visible to the user and could be crushed when leg rest is lowered or when chair is returned to upright position. To avoid serious injury or death, check these areas carefully before reclining, lowering leg rest, or returning chair to upright position.

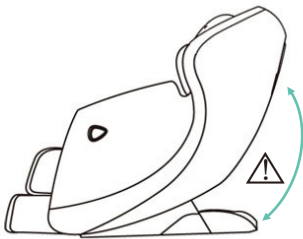

Make sure to check for children or pets between the chair back and the base of the chair before entering zero gravity recline.

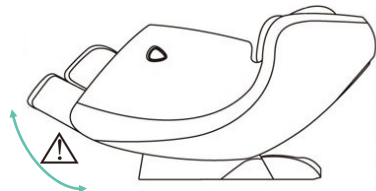

Make sure to check for children or pets between the footrest and the chair body before lowering the leg rest or exiting zero gravity.

Remote Control

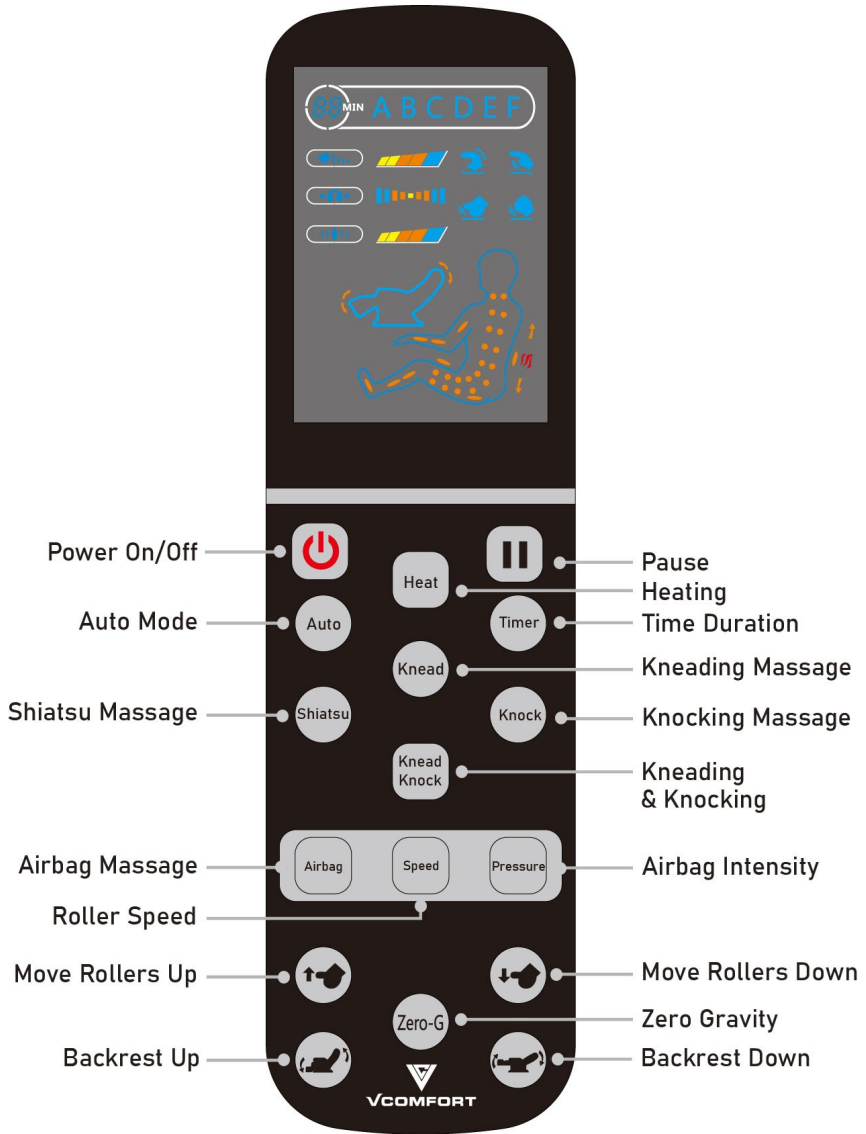

Remote Control Operation



Power ON/OFF: Press to activate the remote. Press again to power off and restore the chair to the upright position.



Pause: Press to pause all functions immediately. Press again to resume.



Auto Programmes: Tap repeatedly to toggle through and select one of six automatic massage programs.



Heat: Press to turn On/Off heat function. The heat icon on display screen will indicate whether heat is turned on/off.



Massage Duration: Tap repeatedly to set your desired massage duration. The timer can be adjusted in 5-minute increments, with a max massage duration of 30 minutes.



Kneading: Press to turn on the kneading function. Kneading is a massage technique that can be used to stimulate muscles and tissues through circular movements.



Shiatsu: Press to turn on the Shiatsu function - targets the acupressure points. It can reduce stress, help with pain and illness, and encourage overall health and wellbeing.



Knocking: Press to turn on the knocking function - stimulate muscles, emulating the percussive massage technique used for deep muscle therapy.



Kneading & Knocking: Press to turn on/off the combination of kneading and knocking function.



Airbag Massage: Press to select your desired airbag region - Full Body, Upper Body, or Lower Body.



Speed: Press this button to adjust the speed of massage rollers.



Airbag Massage Intensity: Press this button to adjust the airbags intensity.



Massage Rollers Move Up: Press and hold this button to move the rollers up to the desired position while using point massage in manual mode.



Massage Rollers Move Down: Press and hold this button to move the rollers down to the desired position while using point massage in manual mode.



Zero Gravity: Press for zero gravity 1, press again for zero gravity 2, press again to return chair to its upright position.



Backrest Up: Press this button to raise the backrest, press again to stop.



Backrest Down: Press this button to recline the backrest, press again to stop.

Auto Programmes

Select from the following auto massage programs.

PROGRAM	FOCUS
A	FULL BODY - Enjoy a comprehensive massage session from neck to toe combines with airbag compression.
B	RELAX - A gentle massage program, using various massage techniques to ease muscles.
C	RELIEF - This program perform the series of massage techniques to relieve muscle tension, improve circulation, and revitalise your energy levels.
D	REST & SLEEP - Try this program before bedtime - helps you unwind from a long day.
E	RECOVERY - A sequence of targeted massage techniques that helps to re-energise tired muscles.
F	CALM - This program is for those looking for a softer massage - beneficial to relax and ease stress when winding down.

Manual Massage Techniques

Manual mode allow you to create a unique massage experience.

MODE	DESCRIPTION
KNEADING	Kneading is a massage technique that can be used to stimulates muscles and tissues through circular movements of rollers.
SHIATSU	Targets the acupressure points. It can reduce stress, help with pain and illness, and encourage overall health and wellbeing.
KNOCKING	Stimulate muscles, emulating the percussive massage technique used for deep muscle therapy.
KNEADING & KNOCKING	Combination of kneading and knocking strokes.

Set your Environment

Timer

Tap repeatedly to set your desired massage duration. The timer can be adjusted in 5-minute increments, with a maximum massage duration of 30 minutes.



Check to make sure children and pets are clear of chair as the chair will return to upright position upon expiry of timer.

Bluetooth Audio

Your massage chair is equipped with a built-in, speaker system to which you can connect via Bluetooth. When your chair is powered ON, the Bluetooth setting is always ON.

Open Bluetooth from audio device and pair with **VComfort T-Rok** to play music.

Frequently Asked Questions

Q: Can I place the massage chair on an electric carpet?

A: No, since the massage chair is heavy, it may damage the heating body of the electric blanket and cause fire. Therefore, do not place it on an electric heating carpet.

Q: What is the recommended user height limit?

A: 150 cm - 180 cm

Q: What is the maximum user weight?

A: 110 kg

Q: Is the product warranty extendable?

A: Yes, the warranty can be extended. If you wish to purchase an additional 1 / 2 years of warranty on top of the manufacturer one year warranty period, please visit this URL <https://www.vcomfort.co.uk/warranty>

Q: What should I do if I spill water?

A: It may lead to an electric shock. Please stop using it immediately and do the following.

- Turn off the power switch behind the massage chair if safe to do so.
- Unplug the power plug from the socket.

Please contact VComfort and arrange technicians visit who will undertake safety checks and reinstate the product.

Q: How do I clean my massage chair?

A: WARNING: Be sure to disconnect the power cord from the electrical outlet before cleaning. When cleaning the remote control or power control box, use a dry cloth only. Never use a damp cloth to clean any electrical component.

CAUTION

- Be sure to test any cleaning solution on a small, inconspicuous part of the product to ensure that the colour does not fade prior to using the solution on the entire product surface.
- Do not use products containing benzene, thinner or alcohol.

To maintain your VComfort massage chair in optimum condition, dust it frequently with a soft dry cloth. If your product becomes dirty, use a water-based upholstery cleaner only.

Trouble Shooting

No.	Symptoms	Possible Causes	Possible Solution
1	Massage Chair does not start	<ul style="list-style-type: none"> The power cord is not secured into the socket Not switched ON The fuse is blown 	<ul style="list-style-type: none"> Insert the power plug properly into the power socket Turn on the switch found on chair side. Then push power button on remote Replace only with a fuse of same type and rating
2	Noise is heard while in use	<ul style="list-style-type: none"> Slight noises are normal and arise from friction between the massage rollers and the faux leather cover Odd, abnormal, or unusually loud noises could be a result of mechanical malfunction 	<ul style="list-style-type: none"> No need to take any measures Please contact VComfort to investigate the issue
3	No music comes from the speaker	<ul style="list-style-type: none"> The volume is turned to the lowest setting Issue with the Bluetooth connection 	<ul style="list-style-type: none"> Adjust the speaker volume from the mobile device The Bluetooth device may not connect to your phone or tablet if it's already connected to another

If problem remains, contact our customer service team at 0333 577 9597, or email info@vcomfort.co.uk

Caution: Do not attempt to repair this product yourself, our company shall not be liable for the injury or damage caused by any servicing without authorisations.

Product Specifications

Model	T-Rok
Max. User Weight	110 kg
Max. User Height	180 cm
Back Wall Clearance	26 cm
Chair Dimensions	120(L) x 72(W) x 115(H) cm
Power Consumption	100 W



VCOMFORT

Safe Store, 198 - 202 Waterloo Road, Birmingham B25 8LD

0333 577 9597

www.vcomfort.co.uk